

Checkweigher Flexus® Highspeed

In-line checkweigher for high process speeds



German Quality

ⓘ Advantages

- Hygienic design for easy cleaning and the highest level of quality in your production operations
- Safety and reliability thanks to EMFC load cell technology
- The ideal solution every time – for your application configure Flexus®
- For process speeds of up to 2.6 m/s



Improve your production efficiency: The Checkweigher Flexus® Highspeed enables fast production processes with speeds of up to 2.6 m/s and meets the highest quality standards.

Ideal for small products in blister or individual packaging

- ⓘ Flexus® is your solution for ensuring optimum product quality, regardless of whether you want to **check the weight** and/or **integrity of your product** or optimise **your filling processes**.
- ⓘ Its hygienic design ensures easy inspection and **cleaning**.
- ⓘ Flexus® is incredibly easy to integrate into your production environment. Changes to line configurations and quick transitions between products are handled **quickly and easily**.
- ⓘ The high-resolution **EMFC load cell technology**, the **extremely sturdy construction** and the exceptionally **powerful motors** guarantee precise weighing results and extremely fast process speeds of up to 2.6 m/s.

Flexible – hygienic – high-performance

The Flexus® Highspeed has been specially developed to comply with guidelines and standards such as IFS and BRC. It is approved for use in legal metrology for FPV (German Prepackages Act) checks, and is MID-compliant in accordance with OIML R51. Thanks to its intelligent, modular construction and hygienic design, the Flexus® Highspeed can be configured to suit your individual requirements, providing you with the ideal solution for any challenge you face.



As a member of the EHEDG, we develop our products based on a wide range of hygienic design guidelines.

Technical data – Flexus® Highspeed

The results achievable in practice, e.g. for the standard deviation attributable to measurement error or the throughput, depend on the relevant application and are therefore not to be considered as absolute values.

| Weighing system | WS 1 kg | WS 2 kg | WS 5 kg | WS 7 kg |
|---|--|---------------------|-------------|-------------|
| Gross weighing range [g] | Up to 1,000 | Up to 2,000 | Up to 5,000 | Up to 7,000 |
| Smallest permissible calibration value [g] | 0.1 | 0.2 | 1 | 1 |
| Standard deviation attributable to measurement error (s) [mg] | From 5 | From 20 | From 100 | From 100 |
| | Depends on product, throughput, ambient conditions and area of application | | | |
| Standard throughput [pcs/min] | Max. 600 | Max. 550 | Max. 450 | Max. 450 |
| | Depends on version, product, permissible imprecision, ambient conditions and area of application | | | |
| Standard speed ranges [m/s] | Up to 2.6 | Up to 2.2 | Up to 1.9 | Up to 1.9 |
| | Verifiable systems only up to 1.5 m/s; higher speeds on request | | | |
| Centre-to-centre distance of weighing belt [mm] | 210/310 | 300/350/400/450/500 | | |
| | See scale drawing and 'Versions' table | | | |
| Belt width [mm] | See 'Versions' table | | | |
| Weighing belt roller diameter [mm] | 22 | 30 | | |
| Drives | Maintenance-free 24 V EC motors with planetary gear Motor control, short-circuit-proof with temperature monitoring | | | |
| Supply voltage | 115/230 V _{ac} (+10%/-15%); 50/60 Hz (L1, N, PE) switchable | | | |
| Power consumption | Approx. 600 VA | | | |
| Operating pressure | Default setting: Pusher: approx. 3 bar Blower: approx. 5 bar | | | |
| Feed direction | Right to left or left to right (please indicate when ordering) | | | |
| Working height* [mm] | 500 to 1,400 with standard adjustable feet 575 to 1,475 with hygienic adjustable feet (adjustable foot range +/-25) * Working height below 650 mm results in limited floor clearance when combined with the collection container option | | | |
| Floor clearance [mm] | 200 with adjustable foot range +/-25 (standard) 275 with adjustable foot range +/-25 (hygienic adjustable feet) | | | |
| Permissible operating temperature range [°C] | 0 to +40 (MID +5 to +40) | | | |
| Conveyor system temperature range [°C] | -10 to +100 (WS 1 kg, belt) -30 to +70 (WS 1 kg, round belt) -30 to +80 (WS 2 to 7 kg, belt) | | | |
| Protection class | IP 54 (standard), IP 65 (optional) | | | |
| Dimensions | See scale drawings | | | |
| Weigher frame material | Stainless steel 1.4301 | | | |
| Weight | 250 kg to 400 kg, depending on version | | | |
| Airborne noise emitted | A-weighted sound pressure level emitted < 70 dB(A) | | | |
| Inputs | 8/16 (optional) digital inputs, 24 V inputs galvanically isolated with a relay or with optocoupler, depending on use | | | |
| Outputs | 8/16 (optional) digital outputs, 24 V outputs galvanically isolated with a relay or with optocoupler, depending on use 2 analogue outputs, 0–20 mA, 0–10 V, for analogue trend controller option Voltage output: Load ≥ 2 kΩ Current output: Load ≤ 300 Ω | | | |

Technical specifications – Checkweigher Flexus® Highspeed

Create your individual Checkweigher Flexus® Highspeed from a wide range of options and function enhancements. We'd be happy to advise you!

| Checkweigher Flexus® Highspeed – standard | |
|---|--|
| Dialogue PC | 10 Flexus®: 10.4-inch TFT colour display with keypad |
| Weight display | choice of gross, net or differential weight |
| Operational display | Choice of distribution, yield, throughput, average value chart, large weight readout |
| Operating modes | Classifying weigher with AWC evaluation; freely selectable class limits; 3-way or 5-way classifying/sorting; statistics with logging of all products; load cell with EMFC technology; product data memory for 200 products; choice of languages for program dialogues, user-selected; self-monitoring via error report; auxiliary functions: dialogues for diagnostics and service, data stored in battery-backed memory, batch mode, automatic zero-setting of the load cell, program-controlled belt speed |
| Digital input | Hide weigher, event counter, external error message |
| Digital output | Feeder/batch, 3-way/5-way sorting, total counter/pre-selection counter, error message output, time-unit-controlled sorting |
| Separation system | One separator including: pusher or blower (depending on product size) |
| Weighing belt | Various lengths and widths |

| Checkweigher Flexus® Highspeed – optional for increased requirements | | |
|--|--|---|
| Connectivity | Fieldbus | PROFIBUS-DP, PROFINET IO, DeviceNet |
| | Data communication | |
| | Factory bus TCP/IP, Ethernet | XML client, XML server, prepared for SPC@Enterprise and OPC DA server |
| | Individual weight value output for external evaluation and connection to customer systems | Serial interface RS 422, RS 232 or current loop |
| | All interfaces specified here are free from feedback and do not need to be secured | |
| Software/programs | SPC@Remote | Remote control for checkweigher – suitable for many different applications |
| | Filling spout evaluation | Statistics for each filling spout and overall statistics possible |
| | Calibration approval | Verifiable in accordance with OIML R 51 - MID |
| | Control functions | Integrity checking/with floating mean value, measuring accuracy check by entering package control weight, automatic sampling of packaging for checking upstream filler |
| | | USB printing |
| | | Logging system for external printer |
| | Volume evaluation | Without air buoyancy correction, with air buoyancy correction |
| Trend controller with display | 3-point controller +/- control signal, 3-point controller with pulse packet, integral controller 0–20 mA/0–10 V | |
| User-defined access control (audit trail) as per FDA 21 CFR Part 11 | Specifications according to FDA requirements (Food and Drug Administration) for data stored electronically and electronic signatures | |
| Control | 3-way/5-way classifying display | 3-way signal light, 5-way signal light, isolated outputs, isolated outputs with 3-way signal light, isolated outputs with 5-way signal light |
| | Separation system | Control of customer sorting/separating equipment |
| | Monitoring functions | |
| | Compressed air monitoring | Isolated output, belt stop |
| | Separation monitoring Goods flow | Isolated output |
| | | Isolated output with belt stop |
| | Package length/interval monitoring | Using additional light barrier |
| | Fill level monitoring Collection container Incorrect weight | Isolated output with light |
| | Production monitoring | Monitoring of average value and repetitive rejections |
| | Sorting with path cycle/ displacement sensor | |
| Mechanical designs | Dialogue PC | 15 Flexus®: TFT colour 15.0 inch, touchscreen |
| | Emergency stop button | Built into PC panel |
| | Incorrect weight collection container | Made from plastic (for products up to 500 g and a maximum belt width of 200 mm) or stainless steel |
| | Separation systems | Rocker, swivel arm, multi-segment separator |
| | Transfer runways | Only for WS 1 kg/2 kg – up to a belt width of 200 mm |
| | Options | Wind protector, covers, LEDs, horn, IP65, guide rail, side-grip belts, stand-alone load cell and weighing belt, separate installation of weighing system and electronics with display and remote terminal, multiline systems, hygienic adjustable feet, additional infeed belt or outfeed belt, pneumatics in stainless steel housing |

Scale drawings

Front view

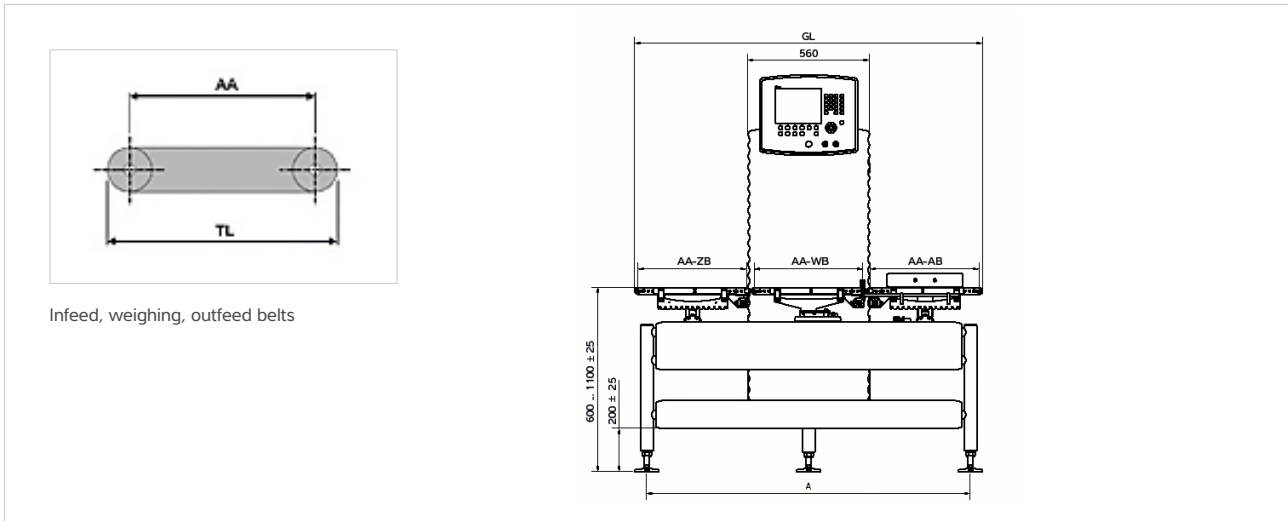

Infeed, weighing, outfeed belts

| | |
|-------|--|
| AA-ZB | Centre-to-centre distance of infeed belt [mm] |
| AA-WB | Centre-to-centre distance of weighing belt [mm] |
| AA-AB | Centre-to-centre distance of outfeed belt [mm] |
| GL | Total length [mm] |
| A | Foot distance [mm] (=GL-110) |
| TL | Platform length [mm] TL = AA + roller diameter (30 mm, or 22 mm in the case of the 1 kg weighing belt) |

Dimensions table: WS 1 kg

| AA-ZB | AA-WB | AA-AB |
|--|-------|---------------------|
| 350/400/450/500 | 210 | 350/400/450/500 |
| 300/350/400/450/500 | 310 | 300/350/400/450/500 |
| Total length GL = AA-ZB + AA-WB + AA-AB + 90 | | |

Dimensions table: WS 2/5/7 kg

| AA-ZB | AA-WB | AA-AB |
|---|-------|---------------------|
| 300/350/400/450/500 | 300 | 300/350/400/450/500 |
| 350/400/450/500 | 350 | 350/400/450/500 |
| 400/450/500 | 400 | 400/450/500 |
| 450/500 | 450 | 450/500 |
| 500 | 500 | 500 |
| Total length GL = AA-ZB + AA-WB + AA-AB + 100 | | |

For belt widths BB = 150/200/250/300, additional lengths are available for infeed and outfeed belts with centre-to-centre distance AA = 550/600/650/700. This creates a larger overhang in relation to the base frame (AA-500+95).

Side view

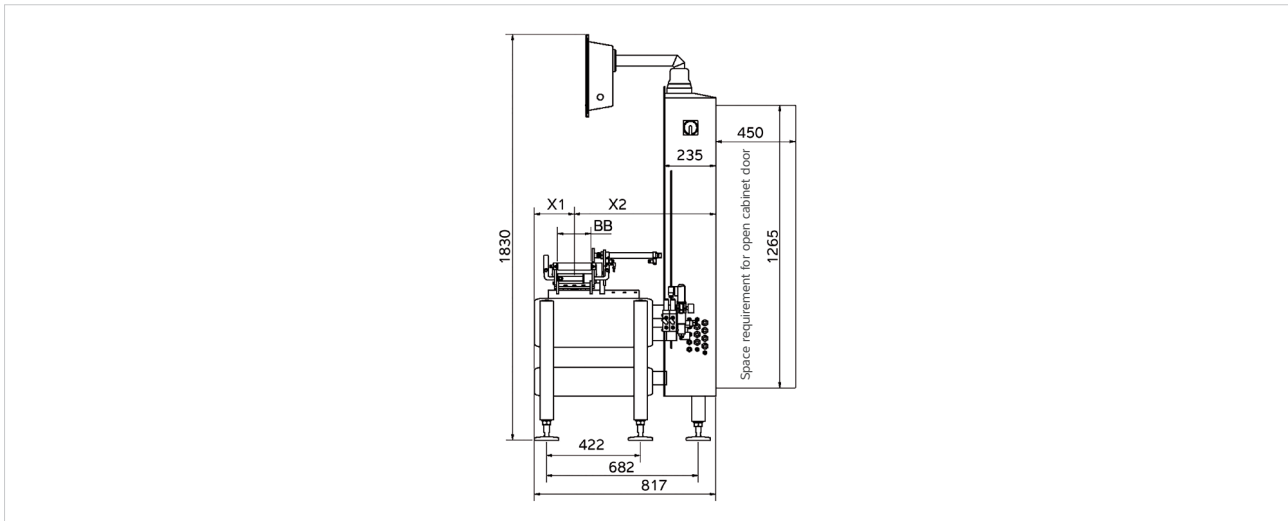

| | |
|----|-----------------------------|
| BB | Belt width |
| X1 | Variable; see scale drawing |
| X2 | Variable; see scale drawing |

| | BB | X1 | X2 |
|-------------|-----|-----|-----|
| WS 1 kg | 50 | 183 | 634 |
| | 100 | 183 | 634 |
| | 150 | 183 | 634 |
| | 200 | 208 | 609 |
| WS 2/5/7 kg | 150 | 183 | 634 |
| | 200 | 208 | 609 |
| | 250 | 233 | 584 |
| | 300 | 258 | 559 |

Versions

| | |
|----|--------------------------------|
| AA | Centre-to-centre distance [mm] |
| BB | Belt width [mm] |
| ● | Round belt or belt version |
| ■ | Belt version |

Dimensions table: WS 1 kg

| BB x AA [mm] | | |
|---------------------------|-----------------|---------------------------|
| Infeed belt ■ | Weighing belt ● | Outfeed belt ■ |
| 150 x 350/400/450/500 | 50 x 210 | 150 x 350/400/450/500 |
| 150 x 350/400/450/500 | 100 x 210 | 150 x 350/400/450/500 |
| 150 x 350/400/450/500 | 150 x 210 | 150 x 350/400/450/500 |
| 200 x 350/400/450/500 | 200 x 210 | 200 x 350/400/450/500 |
| 150 x 300/350/400/450/500 | 50 x 310 | 150 x 300/350/400/450/500 |
| 150 x 300/350/400/450/500 | 100 x 310 | 150 x 300/350/400/450/500 |
| 150 x 300/350/400/450/500 | 150 x 310 | 150 x 300/350/400/450/500 |
| 200 x 300/350/400/450/500 | 200 x 310 | 200 x 300/350/400/450/500 |

Dimensions table: WS 2/5/7 kg

| | AA [mm] | Weighing belt | Outfeed belt |
|-----|---------------------|-----------------|---------------------|
| BB | Infeed belt ■ | Weighing belt ■ | Outfeed belt ■ |
| 150 | 300/350/400/450/500 | 300 | 300/350/400/450/500 |
| | 350/400/450/500 | 350 | 350/400/450/500 |
| | 400/450/500 | 400 | 400/450/500 |
| | 450/500 | 450 | 450/500 |
| | 500 | 500 | 500 |
| 200 | 300/350/400/450/500 | 300 | 300/350/400/450/500 |
| | 350/400/450/500 | 350 | 350/400/450/500 |
| | 400/450/500 | 400 | 400/450/500 |
| | 400/450 | 450 | 450/500 |
| | 500 | 500 | 500 |
| 250 | 300/350/400/450/500 | 300 | 300/350/400/450/500 |
| | 350/400/450/500 | 350 | 350/400/450/500 |
| | 400/450/500 | 400 | 400/450/500 |
| | 450/500 | 450 | 450/500 |
| | 500 | 500 | 500 |
| 300 | 350/400/450/500 | 350 | 350/400/450/500 |
| | 400/450/500 | 400 | 400/450/500 |
| | 450/500 | 450 | 450/500 |
| | 500 | 500 | 500 |

Collection container

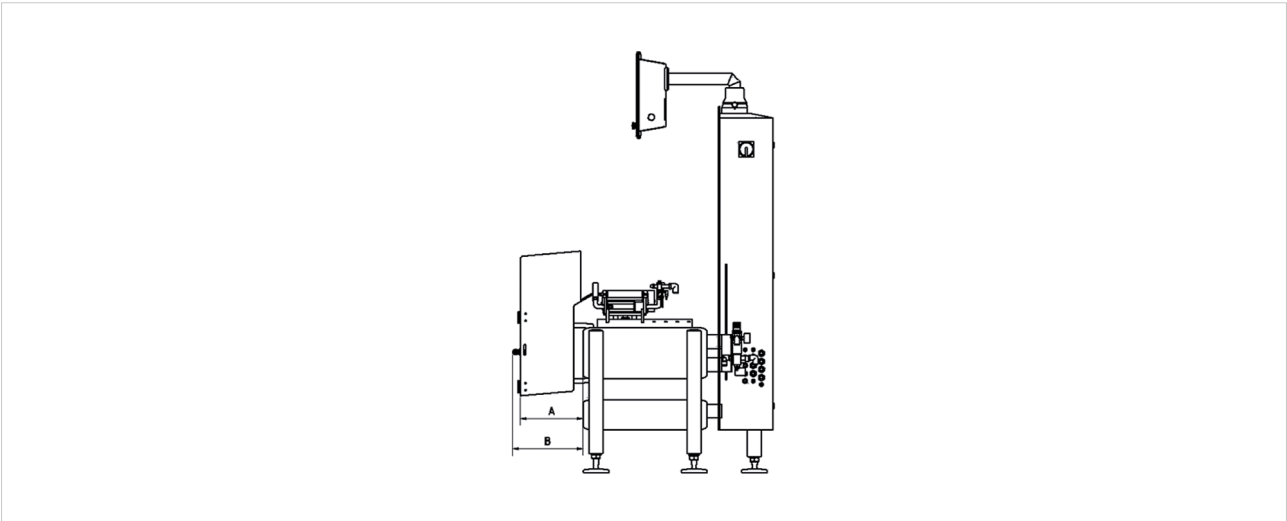

The scale drawing shows Flexus® with a collection container (optional), which is made from plastic or stainless steel – both versions have different dimensions.

A: Minimum depth of the collection container

B: Maximum depth (incl. key) of the collection container

| Material | A [mm] | B [mm] |
|-----------------|--------|--------|
| Plastic | 272 | 303 |
| Stainless steel | 372 | 403 |

Product description

Machine construction

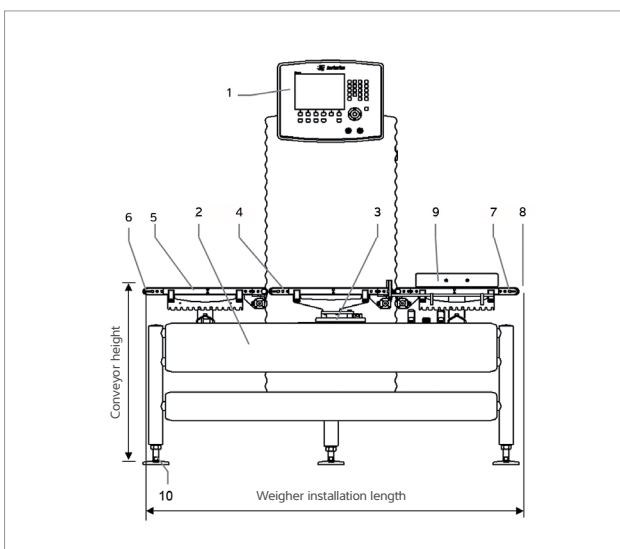

- 1 Display and remote terminal
- 2 Weigher frame
- 3 Load cell
- 4 Weighing belt
- 5 Infeed belt
- 6 Connection to customer infeed belt
- 7 Outfeed belt
- 8 Connection to customer outfeed belt
- 9 Separator
- 10 Spindle adjustable feet

Product description

Machine construction

A three-part conveyor belt system transports the products. All conveyor belts (4, 5, 7) in the system run at the same speed to ensure that products are transferred smoothly onto and off of the weighing belt. The weighing process is carried out dynamically and automatically without intervention by operating personnel. The weight value, including mass unit, is converted and shown on the display.

Weigher frame with control cabinet

Crossbars are fitted to the weigher frame (2). The weighing and transport system is attached to these crossbars. The pillar cabinet with its sinusoidal housing profile is attached to the weigher frame using a clamping device in a form-fitting manner. The working height of the weigher frame is determined by the length of the frame legs. The working height can be adjusted by changing or modifying the frame legs. Small adjustments to the working height can be made via the spindle adjustable feet (10). The display and remote terminal (1) is installed in front of the control cabinet.

Load cell

The load cell (3) is a monolithic, electro-magnetic force compensation load cell (EMFC). This delivers maximum precision, extremely short settling times, high long-term stability and overload protection in a stainless steel housing.

Transport system

A conveyor belt is used as the transport medium (weighing belt WS 1 kg also available with round belt). The belt frame is equipped with a belt quick-clamping device and a hinged, removable transport system. This allows the conveyor belts to be removed/fitted and replaced without tools. The infeed, weighing and outfeed belts are each driven by an EC geared motor. Power is transmitted via toothed belt.

- The infeed belt (5) takes products from the upstream machine and transports them to the weighing belt.
- The weighing belt (4) takes the products from the infeed belt. As the products travel along the weighing belt, they are weighed while they move.
- The outfeed belt (7) takes the products and moves them on.

Control electronics

The display and remote terminal for the weighing function is based on an industrial PC with a powerful 32-bit multitasking operating system with data storage on an internal wear-free compact flash memory card. The housing is made from polished stainless steel. The control cabinet is opened using a continuous cabinet door opening to the rear with fasteners.

The connection terminals for the power supply, the components of the evaluation and display electronics and the power supply unit with motor control are housed in the control cabinet. The main switch is installed in the control cabinet. The start/stop button for the transport system is located on the front of the display and remote terminal (1), which can be swivelled for ergonomic operation.

Separator (9)

Two compressed air nozzles (standard WS 1 kg) or a pneumatic pusher (standard WS 2–7 kg) are fitted on the crossbars of the weigher frame in the outfeed belt area to ensure the reliable rejection of products that have a different weight. A filter pressure control valve is included.